

# KOLJA ELITE



OWNER'S MANUAL

# TABLE OF CONTENTS

1. SAFETY GUIDELINES .....	1
2. SAFETY NOTICE.....	2
3. PARTS INTRODUCTION.....	9
4. OPERATION.....	10
5. BATTERY CHARGING AND CARE.....	14
6. INSPECTION AND MAINTENANCE.....	17
7. TROUBLE SHOOTING AND SPECIFICATION.....	19
8. WARRANTY.....	20

## INTENDED USE

The device is intended for medical purposes to provide mobility to persons restricted to a sitting position for outdoor use..

## SAFETY NOTES:

Maximum safe slope: 8°

The product is not intended for visually impaired people.

The drivers need to be mentally and physically suitable to drive the scooter.

The fingers need to work functionally.

The device can't be used by children until age of 12 without Parent or Professional approval.

The driving distance will be reduced if the power scooter is used frequently on slopes, rough ground or to climb kerbs.

**NOTE:** This owner's manual is compiled from the latest specifications and product information available at the time of publication. We reserve the right to make changes as they become necessary. Any changes to our products may cause slight variations between the illustrations and explanations in this manual and the product you have purchased. The latest/current version of this manual is available on our website.



Issued on Apr. 21, 2020

Version: 1.0

# 1. SAFETY GUIDELINES

Please carefully read this owner's manual before using the scooter. Improper use of the scooter could result in harm, injury or traffic accidents. Therefore for maximum pleasure while using the scooter please read this owner's manual.

- ◆ This owner's manual includes operation instructions for every aspect of the scooter, assembly instructions, as well as instructions for how to deal with possible accidents.
- ◆ The symbols used in this manual are explained below:  
Read especially the notes marked with these symbols:



**WARNING!** Indicates a potentially hazardous condition/situation. Failure to follow designated procedures can cause either personal injury, component damage, or malfunction. On the product, this icon is represented as a black symbol on a yellow triangle with a black border.



**MANDATORY!** These actions should be performed as specified. Failure to perform mandatory actions can cause personal injury and/or equipment damage. On the product, this icon is represented as a white symbol on a blue dot with a white border.



**PROHIBITED!** These actions are prohibited. These actions should not be performed at any time or in any circumstances. Performing a prohibited action can cause personal injury and/or equipment damage. On the product, this icon is represented as a black symbol with a red circle and red slash.

- ◆ This manual includes a copy of repair and maintenance record chart and warranty information. Please keep it in a safe place or in the scooter.
- ◆ If someone else uses the scooter, please make sure that you provide them with the instruction manual for his or her consideration.
- ◆ As designs change some illustrations and pictures in the manual may not correspond to the scooter that you purchased. We reserve the right to make design modifications.

Our scooters have been designed and manufactured to provide a comfortable and secure yet affordable solution for some mobility requirements.



**Suggestion**

To maximize your batteries efficiency and service life, please fully recharge your new battery before its first use.

## 2. SAFETY NOTICE



### GENERALMANDATORY!

Do not operate your new Scooter for the first time without completely reading and understanding this owner's manual and the Consumer Safety Guide.

Your Scooter is a state-of-the-art life-enhancement device designed to increase mobility. We provide an extensive variety of products to best fit the individual needs of the Scooter user. Please be aware that the final selection and purchasing decision regarding the type of Scooter to be used is the responsibility of the Scooter user who is capable of making such a decision and his/her healthcare professional (i.e., medical doctor, physical therapist, etc.).

The contents of this manual are based on the expectation that a mobility device expert has properly fitted the Scooter to the user and has assisted the prescribing healthcare professional and/or the authorized Provider in the instruction process for the use of the product.

There are certain situations, including some medical conditions, where the Scooter user will need to practice operating the Scooter in the presence of a trained attendant. A trained attendant can be defined as a family member or care professional specially trained in assisting a Scooter user in various daily living activities.

As you begin using your Scooter during daily activities, you will probably encounter situations in which you will need some practice. Simply take your time and you will soon be in full and confident control as you maneuver through doorways, on and off elevators, up and down ramps, and over moderate terrain.

Additional general information can be found on the supplemental information sheets and booklets included in your Owner's Package. Please fully read and review the information, and keep it readily available for future reference.

Below are some precautions, tips, and other safety considerations that will help you become accustomed to operating the Scooter safely.

### ■ PRE-RIDE SAFETY CHECK

Get to know the feel of your Scooter and its capabilities. We recommend that you perform a safety check before each use to make sure your Scooter operates smoothly and safely.

### ■ Perform the following inspections prior to using your Scooter:

- ◆ Check the condition of the tires. Make sure they are not damaged or excessively worn.
- ◆ Check all electrical connections. Make sure they are tight and not corroded.
- ◆ Check all harness connections. Make sure they are secured properly.
- ◆ Check the brakes to ensure they operate properly.
- ◆ Check the battery meter to ensure the batteries are fully charged.
- ◆ Ensure the manual freewheel lever is in drive mode before sitting on the Scooter.

If you discover a problem, contact your authorized Provider for assistance. Please refer to the Contact Information insert in your Owner's Package.



## 2. SAFETY NOTICE

### 2.2 WHILE DRIVING

■ **Please carry out daily inspections.** Refer to the section entitled “DAILY CHECKING”

■ **Do not move your body out of the vehicle while moving**

- ◆ Such action may cause you to lose balance and risk injury from falling.
- ◆ Pay attention that your clothes do not tangle in the wheels.

■ **Do not use your vehicle under the circumstances below.**

- ◆ On roads with heavy traffic or roads that are muddy, gravelly, bumpy, narrow, snowed over, icy, or canal towpaths not guarded by any fence or hedge. Keep away from places where you might get the wheels stuck.
- ◆ Do not drive at night or when it is raining, snowing, misty, or windy.
- ◆ Do not drive your vehicle in an “S” pattern or make erratic turnings.
- ◆ Do not take the scooter onto escalators.
- ◆ UNDER NO CIRCUMSTANCES SHOULD THE SCOOTER BE USED AS A SEAT IN A MOTOR VEHICLE (E.G. CARS, BUSES, TRAINS, ETC).

■ **About Mobile Phones and other electrical equipment**

- ◆ Do not use a mobile phone or other wireless communication devices while driving.
- ◆ Always switch off the scooter and remove the ignition key before using a mobile phone.
- ◆ Do not charge the mobile phone or any other electrical devices from your scooter’s battery.

■ **Automatic Power Shut Down**

In order to avoid accidental battery run down, your scooter is equipped with an automatic power shut down facility. If the scooter is switched on, after remaining undisturbed for a period of thirty minutes it will automatically turn off. Should this occur, simply switch your scooter off and back on and it will be ready to use once again.

■ **Ramps, inclines and drops**

- ◆ Do not drive onto steep ramps greater than the specified gradient. Refer to the section entitled “CLIMBING ANGLE” in “7. SPECIFICATION“
- ◆ Always use a low speed setting when ascending or descending a gradient.
- ◆ Do not drive on roads with large drops or potholes.
- ◆ Please slow down when driving on roads with inclines.
- ◆ Do not make sudden turns when driving on gravel roads or ramps.
- ◆ Always lean forward when climbing a steep gradient.

## 2. SAFETY NOTICE

### ■ Starting and Driving

1. Make sure the seat is installed properly.
2. Make sure the tiller has been secured properly.
3. Fold down the armrests so you can rest your arms on them.
4. Turn the power switch to “ON”. If necessary, turn on the headlights.
5. Check battery indicator to see whether there is enough power for your journey. If you have any doubt about the remaining power, please recharge the batteries before departure.
6. Set the speed dial to a position you feel safe and comfortable with.
7. Check the forward/reverse speed lever works correctly.
8. Make sure the electromagnetic brake works correctly.
9. Make sure it is safe around you before you drive on the street. Engage the 6 km/h switch if you are driving on the pavement.

### ⚠ WARNING !

- ◆ Do not set in the freewheel mode when driving on a gradient.
- ◆ Always re-engage the anti-freewheel device before use. Fail to do so may result in injury.
- ◆ To protect your safety, the power will automatically cut off and electromagnetic brake system will activate while you are driving down a steep gradient. This will limit the speed to a safe level. Turn the power on again to re-start your scooter.
- ◆ **Maximum User Weight Limit**  
Refer to section entitled “MAX. USER WEIGHT” in “ 8. SPECIFICATION “. Overloading past the weight limit may lead to damage of your scooter or cause it to malfunction and will endanger your safety. The warranty does not cover this type of damage.

### 📢 Attention

1. Do not push both RH & LH sides of the speed control lever simultaneously. This might leave you unable to control your scooter.
2. Do not turn the power switch to OFF while driving as this will lead to an emergency stop and possible risk of accident and injury.
3. Do not set to the highest speeds while driving indoors.
4. Do not adjust the speed dial while driving, a sudden change in speed may cause danger to you and others, and may cause damage to your scooter.
5. Do not place magnetic devices near the area of the operation handle as this could affect the safe operation of your scooter.
6. Do be careful while driving in heavy traffic or crowded areas.
7. While reversing the vehicle, beware of people or objects behind you.

## 2. SAFETY NOTICE

### ■ Stop the scooter

1. Release the speed control lever completely. The vehicle will naturally brake and stop.
2. Turn the power switch to (OFF). Then pull out the key.

### ■ Driving on the pavement

- ◆ Ensure the limit switch is set to the slowest setting when using the scooter on the pavement.
- ◆ This will limit the scooter to a maximum speed of 6 km/h. It is an offence to travel at more than 6 km/h on the pavement.
- ◆ The limit switch can be set to the fastest setting for use on the road or on private ground.

## 2. SAFETY NOTICE

1. CE LABEL .....



2. WARNING EMI LABEL.....



3. WARNING EMERGENCY FREEWHEEL DEVICE LABEL.....



4. WIRE DIAGRAM FOR BATTERY LABEL.....

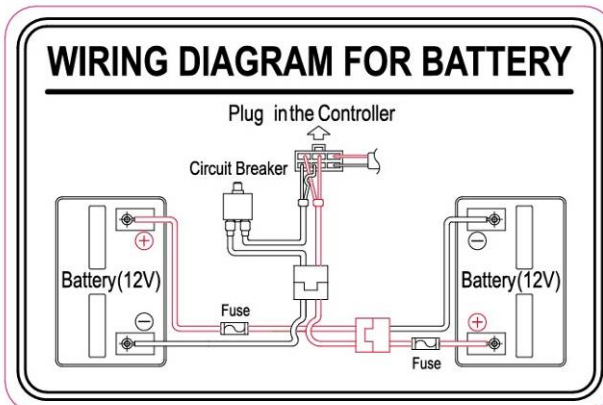

1

2

3

4

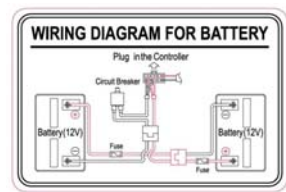

## 2. SAFETY NOTICE

### 2.3 EMI

This portion of the content will provide the user with basic information that describes the problems with EMI, known sources of EMI, protective measures either to lessen the possibility or exposure or to minimize the degree of exposure, and suggested action should unexpected or erratic movement occur.

**Caution:** It is very important that you read this information regarding the possible effects of electromagnetic interference on your electric scooter.

### ■ ELECTROMAGNETIC INTERFERENCE (EMI) FROM RADIO WAVE SOURCES

Powered vehicle may be susceptible to electromagnetic interference (EMI), which is interfering electromagnetic energy (EM) emitted from sources such as radio stations, TV stations, amateur radio (HAM) transmitters, two-way radios, and cellular phones. The interference (from radio wave sources) can cause the powered vehicle to release its brakes, move by itself, or move in unintended directions. It can also permanently damage the powered vehicle's control system. The intensity of the interfering EM energy can be measured in volts per meter (V/m). Each powered vehicle can resist EMI up to a certain intensity. This is called its "immunity level". The higher the immunity level, the greater the protection. At this time, current technology is capable of achieving at least a 20 V/m immunity level, which would provide useful protection from the more common sources of radiated EMI. This powered vehicle model as shipped, with no further modification, has an immunity level of 20 V/m without any accessories.

There are a number of sources of relatively intense electromagnetic fields in the everyday environment. Some of these sources are obvious and easy to avoid. Others are not apparent and exposure is unavoidable. However, we believe that by following the warning listed below, your risk to EMI will be minimized.

The sources of radiated EMI can be broadly classified into three types:

1. Hand-held portable transceivers ( transmitter-receivers with the antenna mounted directly on the transmitting unit. Examples include: citizens band (CB) radios, " walkie talkie", security, fire, and police transceivers, cellular telephones and other personal communication devices.
2. Medium-range mobile transceivers, such as those used in police cars, fire trucks, ambulances and taxis. These usually have the antenna mounted on the outside of the Vehicle,
3. Long-range transmitters and transceivers, such as commercial broadcast transmitter (radio and TV broadcast antenna towers) and amateur (HAM) radios;

# SAFETY NOTICE

## ■ 2.4 EMI

- ◆ This portion of the content will provide the user with basic information that describes the problems with EMI, known sources of EMI, protective measures either to lessen the possibility or exposure or to minimize the degree of exposure, and suggested action should unexpected or erratic movement occur.

### ☠ **WARNING!**

- ◆ It is very important that you read this information regarding the possible effects of electromagnetic interference on your electric scooter.

## ■ **ELECTROMAGNETIC INTERFERENCE (EMI) FROM RADIO WAVE SOURCES**

- ◆ Powered vehicle may be susceptible to electromagnetic interference (EMI), which is interfering electromagnetic energy (EM) emitted from sources such as radio stations, TV stations, amateur radio (HAM) transmitters, two-way radios, and cellular phones. The interference (from radio wave sources) can cause the powered vehicle to release its brakes, move by itself, or move in unintended directions. It can also permanently damage the powered vehicle's control system. The intensity of the interfering EM energy can be measured in volts per meter (V/m). Each powered vehicle can resist EMI up to a certain intensity. This is called its "immunity level". The higher the immunity level, the greater the protection. At this time, current technology is capable of achieving at least a 20 V/m immunity level, which would provide useful protection from the more common sources of radiated EMI. This powered vehicle model as shipped, with no further modification, has an immunity level of 20 V/m without any accessories.
- ◆ There are a number of sources of relatively intense electromagnetic fields in the everyday environment. Some of these sources are obvious and easy to avoid. Others are not apparent, and exposure is unavoidable. However, we believe that by following the warning listed below, your risk to EMI will be minimized.

### **The sources of radiated EMI can be broadly classified into three types:**

4. Hand-held portable transceivers (transmitter-receivers with the antenna mounted directly on the transmitting unit. Examples include citizens band (CB) radios, "walkie talkie", security, fire, and police transceivers, cellular telephones and other personal communication devices.
5. Medium-range mobile transceivers, such as those used in police cars, fire trucks, ambulances and taxis. These usually have the antenna mounted on the outside of the Vehicle.
6. Long-range transmitters and transceivers, such as commercial broadcast transmitter (radio and TV broadcast antenna towers) and amateur (HAM) radios.

# PARTS INTRODUCTION

## ■ 3.1 PARTS DESCRIPTION

- |                                 |                     |                                    |
|---------------------------------|---------------------|------------------------------------|
| 1. Indicator Lamp.              | 2. Basket.          | 3. Seat Remove Lever.              |
| 4. Head Lamp.                   | 5. Headrest.        | 6. Armrest.                        |
| 7. Seat Remove Lever.           | 8. Side Reflector.  | 9. Width Adjustable Armrests Knob. |
| 10. Freewheel Lever.            | 11. Rear Reflector. | 12. Rear Lamp.                     |
| 13. Anti-tip Wheel.             | 14. Rear Mirror.    | 15. Storage bag.                   |
| 16. Control stand push-up/down. | 17. Storage Box.    |                                    |





# OPERATION

## 4.1 CONTROL PANEL

1. Monitor. (Power, speed, time, temperature, kilometer)
2. Speed adjustment button. (Fast/slow)
3. Speed lever. (Forward)
4. Speed lever. (Back)
5. Speed button. (Up)
6. Speed button. (Down)
7. Horn.
8. Time.
9. Headlight.
10. Right direction light.
11. Warning triangle.
12. Left direction light.



## 4.2 HOW TO OPERATE YOUR SCOOTER

### Power switch

- ◆ Turn the key to power ON or OFF.  
(ON) : Power is turned on.  
(OFF) : Power is turned off.

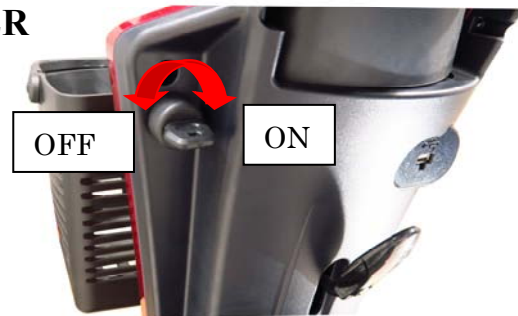

### Speed Dial

- ◆ Press the slowest or fastest setting to determine the maximum speed of the scooter.



### Forward, Reverse, and Braking

- ◆ Pull the speed control lever backwards with your right fingers and the vehicle will move forward.
- ◆ Pull the speed control lever backwards with your left fingers and the vehicle will move backward.
- ◆ The horn will beep when the vehicle is in reverse.
- ◆ Release the speed control lever freely while either going forward or reverse, and the electromagnetic brake in the motor will be activated, and the vehicle will stop.

### Indicator Lamp Switch

- ◆ The light will flash, and buzzer will make a beeping sound when turning the switch to the left or right.
- ◆ Return the switch back to the middle, the indicator will be cancelled.

# OPERATION

## ■ Horn Button

- ◆ Press the horn button to sound the horn. Release the button to stop the horn.

## ■ How to Set Drive mode and Manual mode

The motor on the scooter can be disengaged to allow the scooter to be pushed.

### ◆ Drive Mode

To put the scooter in to “Drive” mode, push the drive lever down completely.

### ◆ Manual Mode

To put the scooter in to “Manual mode” push the manual lever up completely and the scooter can be moved manually.

- ◆ Please note that this will put the scooter in to drive mode, so scooter’s motor and brake will be disengaged.

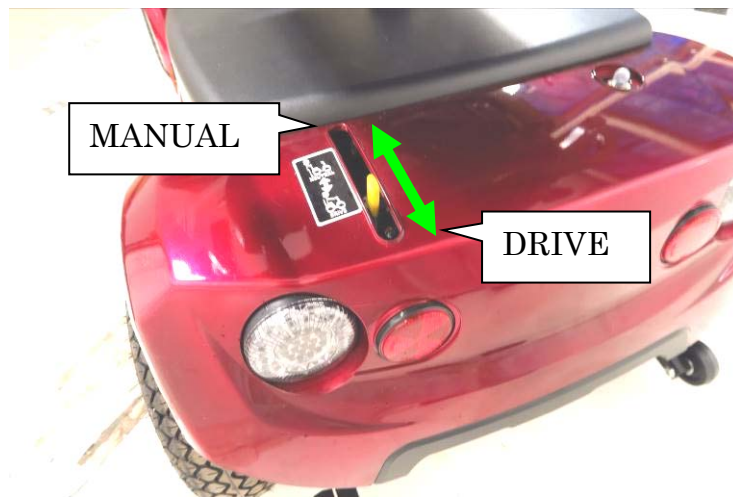

## ■ Battery Indicator

- ◆ The battery indicator on the console uses a color code to indicate the approximate power remaining in your batteries. Green indicates (40~100%) capacity, yellow a draining charge(10~30%),and red indicates that an immediate recharge is necessary.
- ◆ The remaining power suggested by the battery indicator will vary by the actual driving time incurred and how you drive. Repeated starting, stopping, climbing will consume the power more quickly.



Battery Power

# OPERATION

## ■ Braking

- ◆ Electro-magnetic brake:
- ◆ Release the speed control lever completely, and the electromagnetic brake will be activated automatically, and the scooter will stop.

## ■ Parking

- ◆ After stopping, tune the main key to OFF and remove the key. The lights will turn OFF. The electromagnetic brake is engaged (locked).

## ⚠ Warning

- ◆ When on a gradient, NEVER switch the vehicle to the freewheel mode.
- ◆ The electromagnetic brakes will not be applied. This may result in injury.

## ■ How to adjust the armrest width and height

- ◆ Loosen the knobs at the back or side of the seat frame firstly, then adjust the armrest width or height by sliding the armrest. Once satisfied with the width, tighten the knob.



## ■ Seat

- ◆ The seat can be turned to 45 degrees or 90 degrees.
- ◆ Pull the seat adjustment lever forward and swivel seat.
- ◆ Release the lever, then continue swiveling the seat until it locks in position.

## ☞ Attention

- ◆ Return the seat to the forward position before driving.
- ◆ Ensure the limit switch is set to the slowest setting when using the scooter on the pavement.

# OPERATION

## ■ How to re-position the seat

- ◆ The seat can be slide backward and forward for a comfortable driving position.
- ◆ To slide the seat, pull the lever at the front of the seat and reposition as required.



## ■ PUSH Adjustment

- ◆ The PUSH can be adjusted into many different positions to suit each driver.
- ◆ PUSH or Pull the positions you want.



## ■ Main Circuit Breaker (Reset Button)

- ◆ When the voltage in your scooter's batteries becomes low or the scooter is heavily strained because of excessive loads or steep inclines, the main circuit breaker may tip to protect the motor and electronics from damage.



# BATTERY CHARGING AND CARE

## ■ 5.1 CHARGING THE BATTERY

◆ Follow the procedure below step by step:

1. Turn the power switch to (OFF).
2. Connect the charger's power cord into the power outlet.
3. Open the charging socket cap on the scooter's tiller. Then connect the charger's round plug to the charging socket.
4. Turn on the switch on the charger.
5. Both the charger's red and orange LEDs will be lit when beginning charging. The charging duration is about 8 hours. To ensure optimum performance a 10-hour charge is recommended. But we do not recommend a charging more than 24 consecutive hours.
6. Both the charger's LEDs will be lit during the charging process. The orange LED will turn green when charging is complete.
7. Turn off the charger; disconnect the power cord and the round plug from charger socket on the scooter.



### ⚠ Warning

1. There is a red LED present on the charger to illustrate operation. If this LED does not illuminate the charger is defective, please contact your dealer.
2. Keep away from flammable objects while charging as it may lead to fire or explosion of battery.
3. Do not smoke while charging as the battery may release hydrogen gas. Always charge your battery in a well-ventilated space.
4. Never connect or disconnect the plug or cord with wet hands while charging.
5. Do not connect or disconnect the plug or cord when they are wet, it may lead to electric shock.

### 👉 Attention

- ◆ While gripping or folding the handlebar, beware of finger or hands caught in the handle area.
- ◆ While returning the battery pack to the battery pack cavity of shroud, beware of finger or hands.

**NOTE:** The immovable function will be activated while your scooter is in charging status, which will make your scooter not run.



# BATTERY CHARGING AND CARE

**☞ Attention - Please follow the rules below to avoid accidents while charging.**

1. Please use the WU'S charger only and recharge the battery to its full capacity every time. You may damage the battery and scooter if you use a charger, which is not to the correct specification.
2. Please charge in a well-ventilated space where it is not directly exposed to the sunlight.
3. Do not charge in surroundings where it is humid or under rainfall and morning dews.

## ■ 5.1 BATTERY

- ◆ Do not expose the battery to temperatures below 10°C or above 50°C when charging or storing the vehicle. Under the above temperature range can cause the battery either to freeze or overheat. This will damage the batteries and shorten their life.
- ◆ These batteries are maintenance free and there is no need to refill with water.
- ◆ You are required to recharge the batteries on a regular basis. Even if the scooter is stood idle, you should charge the batteries at least once a week.
- ◆ The batteries carry a six-month manufacturer's warranty. This warranty only covers issues relating to manufacturing faults, and not faults relating to failure to recharge the batteries as instructed above.

**📖 Suggestion – How to maximize your batteries efficiency and service life**

1. Always complete the charging until the orange LED light turns green. NEVER stop charging before it is complete.
2. Keep your batteries fully charged whenever possible.
3. If you do not use your scooter for a long time, it should be charged at least every week to keep the battery in a fully usable condition.
4. The ambient temperature will affect charging time. Charging time will be longer in the winter.
5. After charging, do not leave the charger socket plugged in to the scooter, as this will cause a power drain on the scooter and temporarily reduce its range.

# BATTERY CHARGING AND CARE

## ■ Cleaning the battery

◆ If the batteries are contaminated by water, battery acid, dust or other substances, they will discharge quickly. The batteries supplied with the WU'S scooter are sealed and as such are maintenance free with no risk of battery leakage. Please follow the steps below to clean the battery.

1. Turn the scooter power switch to "OFF".
2. Remove the seat and dust cover.
3. Remove the shroud and unplug the terminal of the taillight and signal lights.
4. Use a clean cloth to wipe off the soiled area.
5. Take out the battery.
6. Clean the battery with a clean cloth. If the terminal is covered by white powder, please wipe it clean using warm water.

## ⚠ Warning

1. The wiring system and charger are well situated in battery pack while assembled in plant.
2. Do not attempt to re-locate the wiring system by yourself. The improper layout of wiring system may result in the wires pinched by battery box, which might the electronic system failure.
3. Be sure the battery wires are connected to their right battery terminal.

## 📖 Suggestions

1. Make sure the terminals are installed properly and put the cover back on.
2. Do not use the battery to charge telecom equipment or other items.
3. Battery efficiency will vary with outside conditions; the driving distances will be shorter in the winter. If the vehicle is not used for a long time, please charge the battery at least every week.
4. Replace both batteries together.
5. If necessary, ask for help from your dealer for advice about maintaining and replacing the battery.

## ■ USB and Storage Box

◆ The USB charging stand is only used for charging mobile devices. It does not have any function of connecting with a computer. It is convenient for the portable devices to provide power immediately to avoid running out of electricity. There is also a storage box for mobile devices and portable items.





# INSPECTION AND MAINTENANCE

## ■ 6.1 INSPECTION

- ◆ Clean the scooter with a damp cloth and dust down approximately once a week to preserve the appearance of the scooter.
- ◆ Adjust the tiller height and return to the original position and swivel the seat once a week to ensure the parts adjust and remove smoothly and easily when required.
- ◆ Check for signs of wear and tear on the tires and the upholstery on a regular basis.
- ◆ For optimum performance and to increase the lifespan of your scooter, it is recommended that you have your scooter serviced once a year.

## ■ 6.2 REGULAR CHECKING RECORD

- ◆ To make sure your scooter is correctly serviced, take it to your dealer for regular maintenance checks. This should be at intervals of six months after the first inspection after one month. Your dealer may charge a fee for this service.

YEAR	1	2	3	4	YEAR	1	2	3	4
Service Dates					Service Dates				
Controller					Upholstery				
On/off switch					Seat				
Controller Lever					Back				
Braking					Armrests				
Recharge point					Electrics				
Batteries					Connections condition				
Levels					Lights				
Connections					Test run				
Discharge test					Forwards				
Wheels and Tyres					Reverse				
Wear					Emergency stop				
Pressure					Left turn				
Bearings					Right turn				
Wheel nuts					Slope test				
Motors					Over obstacles				
Wiring					List Items repaired				
Noise									
Connections									
Brake									
Brushes									
Chassis									
Condition									
Steering									

## ■ 6.3 BATTERY, FUSE AND TYRE

### ■ Battery

- ◆ Refer to the section entitled “5.2 BATTERY” in “5. BATTERY CHARGING AND CARE”.

### ■ Fuse

- ◆ If the battery charger is turned on and no LEDs are lit, check the fuse.

## Suggestion

- ◆ Ask for help from your scooter dealer to inspect or replace the fuse, since the tiller shroud has to be removed first before you can replace the fuse.

## ■ Tires

- ◆ The condition of the tires depends on how you drive and use your scooter.
- ◆ Inspecting tire tread.
- ◆ Please check the tread groove regularly. Replace the tires when the tread groove is less than 0.5 mm.

## Attention

1. When tread groove is below 0.5mm it can easily lead to vehicle slippage, making braking distances longer. therefore, replace the tires as early as possible when they do not have insufficient tread depth.
2. The tire pressure shall be kept at about 26 PSI (approx. 1.8KG/cm) for the best ride and handling.
3. When conducting maintenance of your vehicle, please turn the power switch to OFF and remove the charger cords.

## ■ 6.4 STORAGE

- ◆ Make sure the vehicle is stored under the following circumstances:
- ◆ Make sure the seat is set in the “Forward” position.
- ◆ Make sure the Power switch is turned to OFF.

## Suggestion

- ◆ Please store the scooter in a location where it is away from the direct sunlight, rain, or dew.
- ◆ When storing for a long time, please charge the battery to full power and then disconnect the battery terminal. For details inquire to your scooter dealer.

## ■ 6.5 MOVING ABOUT

- ◆ Turn the power switch “OFF” before moving.
- ◆ Lift the scooter by the chassis, and not by the bumpers. Lifting the scooters by the bumper could cause damage or injury.
- ◆ For your safety, always ask for help if required. You will need 2 or 3 persons when moving or lifting the vehicle.

# TROUBLE SHOOTING AND SPECIFICATION

## ■ TROUBLE SHOOTING

Problems	Solutions
The scooter will not switch on	<ul style="list-style-type: none"> <li>• Try recharging the battery</li> <li>• Check the fuse and circuit breaker in the scooter</li> </ul>
The scooter switches on, but the scooter will not move.	<ul style="list-style-type: none"> <li>• Ensure there is enough power in the batteries. If not, recharge the batteries.</li> <li>• Ensure the freewheel lever is engaged in the 'DRIVE' position.</li> </ul>
The scooter appears slow	<ul style="list-style-type: none"> <li>• Check the battery power level and recharge</li> <li>• Check the speed dial is not set to slow.</li> </ul>
The seat turns when in operation	<ul style="list-style-type: none"> <li>• Slowly rotate the seat until it drops in to place and is secure</li> </ul>
The handlebar appears loose	<ul style="list-style-type: none"> <li>• Tighten the height adjustment handle to secure the handlebar</li> </ul>
Involuntarily horn sounds	<ul style="list-style-type: none"> <li>• Ensure that the wigwag paddle is released.</li> <li>• Switch the scooter off and on.</li> <li>• Recharge the batteries.</li> <li>• If problem, persist contact your WU'S dealer.</li> </ul>

## ■ SPECIFICATION

Model Reference	KOLJA ELITE
Dimension (L x W x H mm)	1370 x 670 x 1320 mm
Weight w/i battery without battery	106.3kg
	75.2kg
Battery	12V x 50Ah x 2pcs
Charger	24V 5A off Board
Front Tire	4.00-5 X 2 AIR TIRE
Rear Tire	4.00-5 X 2 AIR TIRE
Driving System	Direct drive the rear wheels (with differential gear)
Brake System	Electromagnetic brakes
Control Method	By speed control lever
Top Speed	15km
Climbing angle	8°
Cruising range	30km
Max. user weight	350Ibs / 160kg

The manufacturer reserves the right to modify the specification if necessary. The final specification is subject to the individual scooter you purchase from your dealer.

Note: Please note that the maximum range is based on an ambient temperature of 20°C, a 75kg driver, a brand New and fully charged battery, and a constant driving speed of 4/5 mph with 70% battery power discharged.

# WARRANTY

## **TWO-YEAR LIMITED WARRANTY**

Structural frame components, including: platform, fork, seat post, and frame welds.

Drivetrain, including: differential, motor, and brake.

Your Pride scooter is fully guaranteed for two (2) years from the date of purchase against faults arising due to defects in manufacture or materials. This warranty does not detract from but is in addition to your legal rights.

All electronic parts, including controllers and battery chargers, have a two (2) year warranty. Servicing to the controller or battery charger must be carried out by your authorized Pride Provider. Any attempt to open or dismantle these items renders the guarantee void on that item.

## **NOT COVERED UNDER WARRANTY**

This guarantee does not extend to those items which may need replacement due to normal wear and tear (tires, belts, bulbs, upholstery, plastic shrouds, motor brushes, fuses, and batteries) or damage to the product caused by misuse or accident for which Pride or its agents cannot be held responsible. This warranty does not include labor or service calls.

## **BATTERIES**

Batteries are covered by a six (6) month warranty from the original manufacturer.

Gradual deterioration in performance due to being left in a discharged state, left in cold conditions for long periods of time, or worn out through heavy use is not covered.

## **SERVICE CHECKS AND WARRANTY SERVICE**

Warranty service can be performed by your authorized Pride Provider. Please contact your authorized Pride Provider for advice on current cost affecting the service visit.

## **REPLACEMENT UNITS**

The availability of replacement units is subject to the discretion of the provider, not the manufacturer. For more information regarding replacement units, contact your authorized Pride Provider.













*NOTE: Pride Mobility Products Europe B.V. provides parts only under warranty. Your Pride Provider is responsible for labor and service. Please contact your Pride Dealer for information about the services and for any applicable charges.*

## Product label indication.

The product label with SN number is located on the main shroud of the scooter as well as on a label in the user's manual.

Importer label

Manufacturer label

 WU'S TECH (Vietnam)CO.,Ltd NO.31, Vsip II, Road 6,Thu Dau Mot City, Binh Duong Province, Vietnam	Manufacturer
 2020-04	Month of Manufacture
	Serial Number
	Model Name
	Importer
	Medical Device
	You must follow the instruction in the user's guide
	CE mark
	EMI/EMC
	Must not be disposed of as household waste
	Max. Weight capacity
	EU representative