

PRODUCT SPECIFICATIONS SHEET

Model: Colt Plus (SC710)

Document Information: INFINF B2694/Rev D/September 2019

Model Number	SC710
Class of Use	B
Weight Capacity	159 kg; 25 stone (350 lbs.)
Maximum Speed ¹	Up to 6.4 km/h (4 mph)
Ground Clearance ²	57 mm (2.25 in.) at motor
Turning Radius ²	1370 mm (54 in.)
Overall Size ^{2, 6}	Length: 1194 mm (47 in.) Width: 560 mm (22 in.)
Tyres	Front and rear: 254 mm (10 in.) pneumatic tyres
Range ^{1, 4}	Up to 25 km (15.5 miles)
Total Weight Without Batteries ^{2, 5}	64.5 kg (142.5 lbs.)
Heaviest Piece when Disassembled	Front Section: 29.75 kg (65.5 lbs.)
Standard Seating	Type: Foldable Molded Plastic Weight: 12 kg (26.5 lbs.) Material: Black Vinyl Dimensions: 460 mm (18 in.) overall width 432 mm (17 in.) effective depth
Drive System	Rear-wheel drive, sealed transaxle, 24-volt DC motor
Dual Braking System	Regenerative and electromechanical
Battery Requirements ^{3, 6}	Two 12-volt, sealed lead-acid, non-spillable, deep-cycle Size: 32 Ah; Optional 40 Ah Battery Weight: 10 kg (22.5 lbs.) each 32 Ah Battery Weight: 14.75 kg (32.5 lbs.) each 40 Ah
Battery Charger	Off-board
Maximum Allowable Incline	10.5% (6°)
Maximum Angle Capacity	17.6% (10°)
Maximum Obstacle Climbing Ability	50 mm (2 in.)

¹ Varies with user weight, terrain type, battery amp hour rating (Ah), battery charge, battery condition, motors, controller type, tire type, and tire condition. This specification is subject to a variance of +10%, -5%.

² Due to manufacturing tolerances and continued product improvement, this specification can be subject to a variance of (+ or -) 3%.

³ AGM, Gel-Cell, or Hybrid Gel (Hybrid Gel is defined as Nano Silica Gel Electrolyte with High Quality Glass Mat Separators) type required. See III. "Batteries and Charging."

⁴ Tested in accordance with ANSI/RESNA, WC Vol. 2, Section 4 & ISO 7176-4 standards. Results derived from theoretical calculations based on battery specifications and drive system performance. Test conducted at maximum weight capacity.

⁵ Includes standard seat.

⁶ Battery weight may vary based on manufacturer.

⁷ Tested in accordance with ISO7176-22, 2000 and ISO 7176-11, 1992 standards.

NOTE: This product conforms to all applicable ANSI/RESNA, ISO 7176 Series, AS/NZS 3695.2, and EN12184 standards. All specifications subject to change without notice.



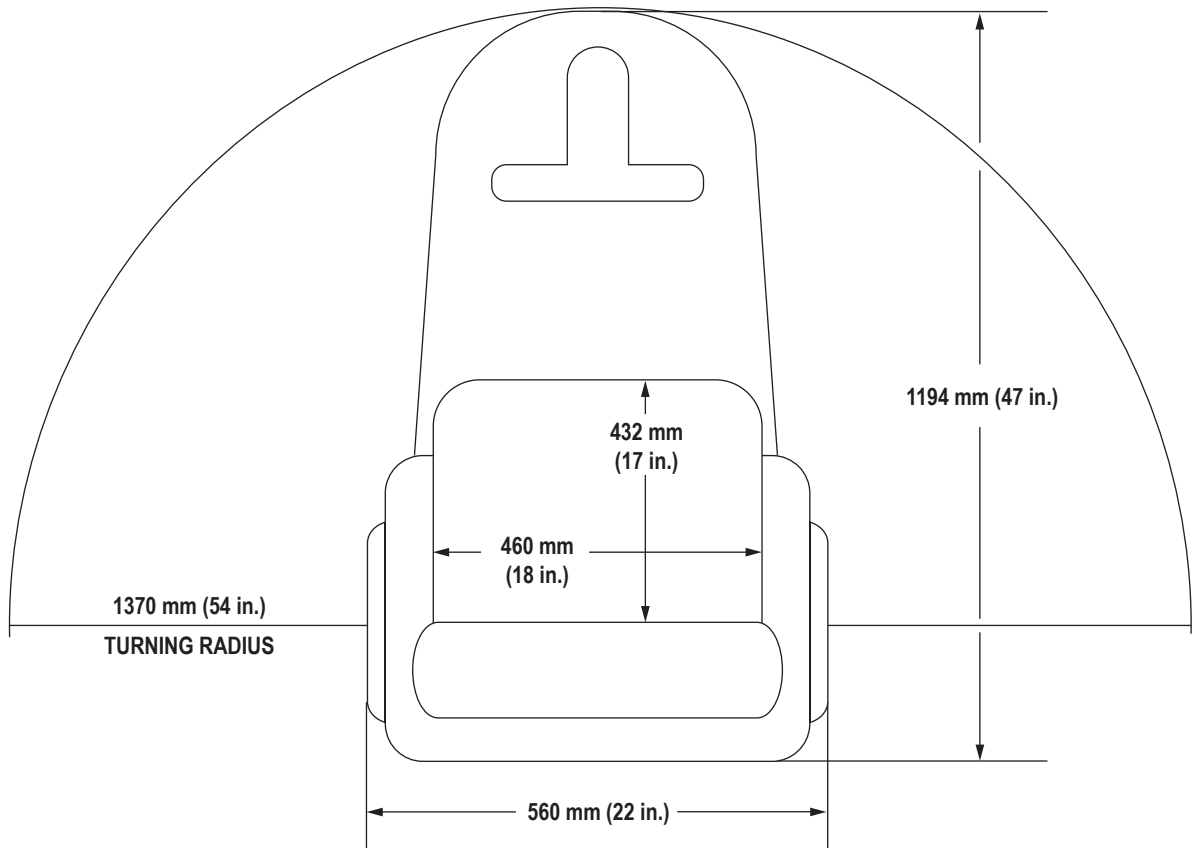
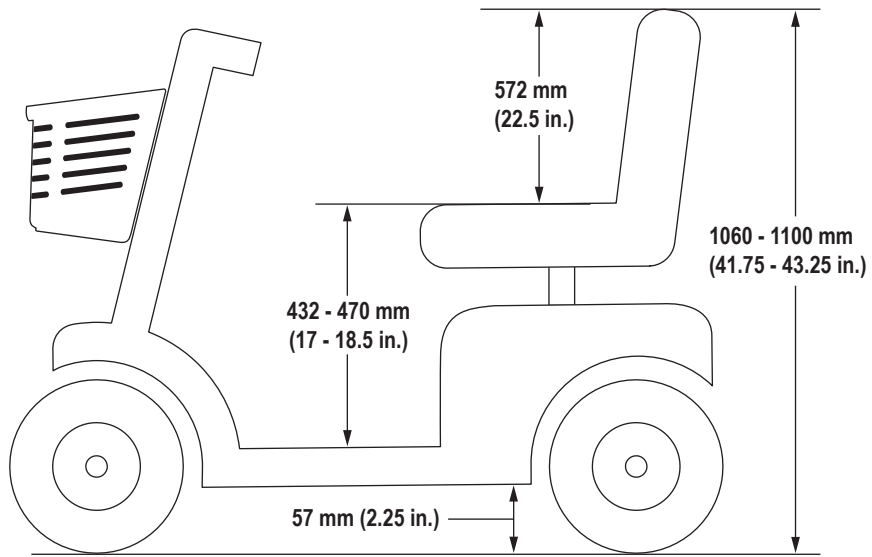

Colt Plus (SC710) Dimensions

